

PROGRAMMING YOUR SYSTEM Open the battery compartments on the pager and transmitters. Locate the digital code panel (DIP switch) in each unit. Carefully slide the 8 switches up or down to form a pattern which will be your own personal code. (Example: 4 up and 4 down). **NOTE: Be sure to code your pager and all your transmitters with the same pattern.**

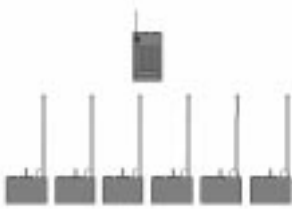

ATTACHING THE TRANSMITTER Attach one of the enclosed velcro strips to the bottom of the transmitter. Place the other velcro strip on the tip-up and attach the transmitter to it. Refer to the illustrations (below left) for the proper position in which to place the velcro for each style tip-up used. **Surfaces must be room temperature and dry.** Tie one end of the string to the metal clip (included). Attach the metal clip to your tip-up flag while in the set position. Leaving a small amount of slack in the string, measure and tie the other end to the transmitter trip key.

Any number of transmitters can be coded to activate a single pager.



STRIKE SENSOR®

Electronic Fishing System

INSTRUCTIONS

For use with tip-ups, set poles and bank fishing rods.

ATTENTION:

If this new product is not compatible with a Strike Sensor version you already have, or to purchase additional units for earlier versions, call customer service at 920-533-3624.

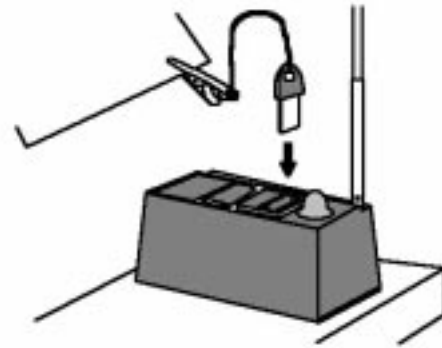

BASIC USE Attach the transmitter to a set tip-up. Insert the trip key into the slot on the top of the transmitter and clip the other end to the flag. Switch the transmitter "ON" and extend the antenna. Switch the pager unit "ON" and press "RESET". Your system is now active.

MONITORING ICE FISHING TIP-UPS

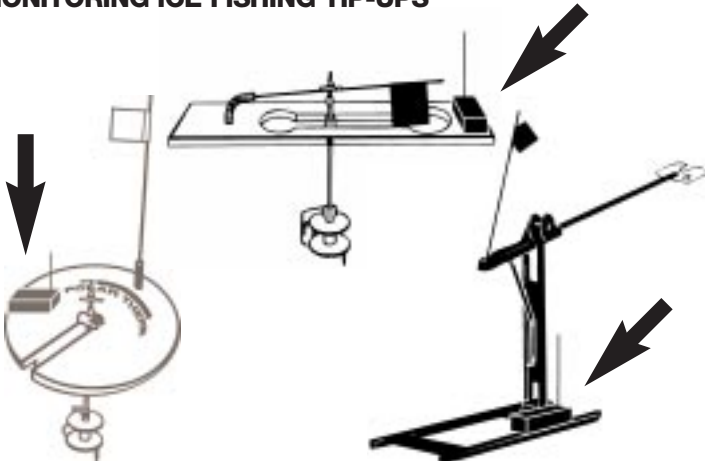

TESTING THE PAGER BATTERY The pager is equipped with a battery tester. To test, turn unit ON, press and hold the RESET button. A solid, continuous "BEEEEEP" indicates a good battery. No sound (only LED light) indicates a weak battery which should be replaced. **To prolong battery life, be sure units are turned off when not in use.**

EFFECTIVE RANGE AND TRANSMISSION DISTANCE Strike Sensor works on a powerful FM radio signal that has worked in tests up to 650 feet. Your reception distance will vary depending upon atmospheric conditions. For optimal range, the area between the pager and transmitters should be unobstructed and in a direct line of sight. **The pager antenna wire must be straight up.** Carry the pager with the antenna outside your clothing in a chest pocket or as high as possible. **The higher the pager is elevated from the transmitters, the better the reception.** When fishing from a metal shanty or lake cottage, place the pager in a window facing the transmitters. Precipitation can reduce range.

NOTE: Avoid condensation in the units. After each outing, bring units indoors. Clean well, and store in a dry place.

BATTERY INSTALLATION Install a 9 volt battery in the pager and transmitters as the diagram in the battery compartments illustrate. **Be sure all battery connections fit tightly.**

In the transmitter, coil excess wire immediately in front of the battery, making sure there is no wire above or below the battery itself. Wire from the battery to the DIP switch compartment should be tucked into the crack along side the compartment divider.

Note: For optimum cold weather operation, always use alkaline or lithium batteries.

The pager can also be powered using an optional AC or DC adapter. The AC/DC adapter plugs into the jack on the side of the pager. These adapters will override an installed battery and are readily available in the electronics department of most stores.

Adapters with an output of 9V DC 500mA are recommended.

FCC COMPLIANCE This equipment has been tested and found to comply with the limits for a class B digital device, pursuant to part 15 of the FCC Rules. These limits are designed to provide reasonable protection against harmful interference in residential installation. This equipment generates, uses and can radiate radio frequency energy and, if not installed and used in accordance with the instructions, may cause harmful interference to radio communications. However, there is no guarantee that interference will not occur in a particular installation. If this equipment does cause harmful interference to radio or television reception, which can be determined by turning the equipment off and on, the user is encouraged to try to correct the interference by one or more of the following measures:

- Reorient or relocate the receiving antenna
 - Increase the separation between the equipment and receiver
 - Connect the equipment to an outlet on a circuit different from that to which the receiver is connected
 - Consult the dealer or an experienced radio/TV technician for help
- Changes or modifications not expressly approved by SensorTronics, Inc., can void the user's authority to operate the equipment.

**MONITOR BANK FISHING
RODS & SET POLES
LINE RELEASE METHOD**



To assemble line release, slide the red rubber caps onto the jaws of the metal clip.



Tie the string onto the tab next to the key slot on the transmitter. Leave 1-1/2" of string. Then tie on the transmitter key. Finally, tie the end of the string to the clip/release.
Position transmitter below set pole. Clip release to the line. As a fish takes up slack, the key is lifted from the transmitter.
Add split shot weights to the string to acquire desired tension for fishing with live bait, in wind or in current.
Secure transmitter, using the enclosed velcro, to the dock, rod holder, plywood, or optional Line Minder (see below).

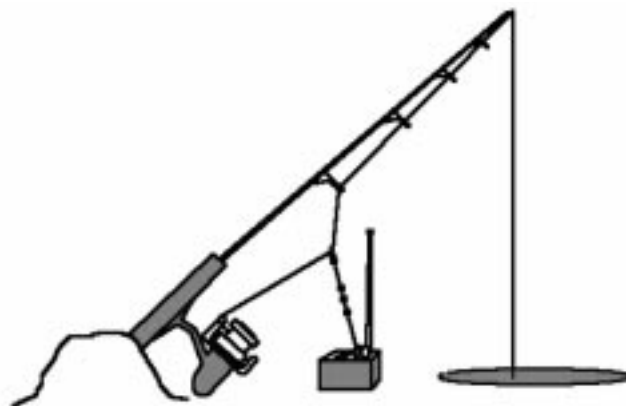

ICE FISHING SET POLE

PAPER CLIP METHOD

Attach a small paper clip to the transmitter trip key. Set your line.

Create a small amount of slack and hook the paper clip/key to the slack line.

Position the transmitter below the rod and insert the trip key. Extend antenna and turn the unit "ON".

System is now ready to alert you the instant a fish strikes and takes up the slack.

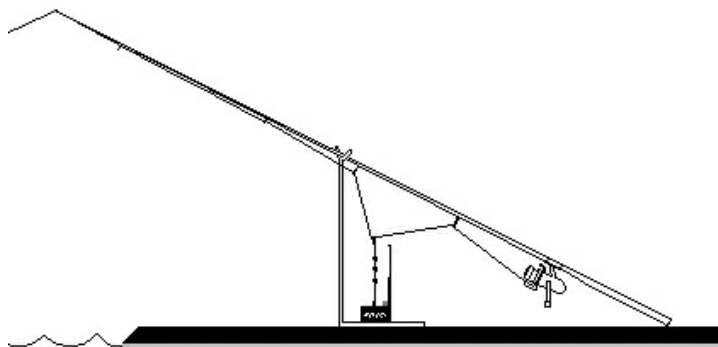
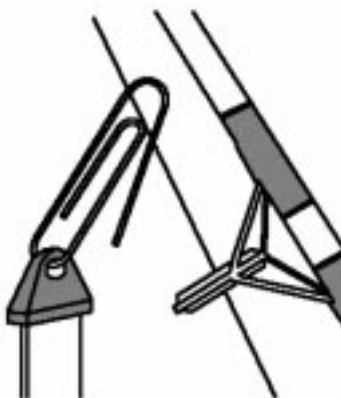

BANK FISHING ROD

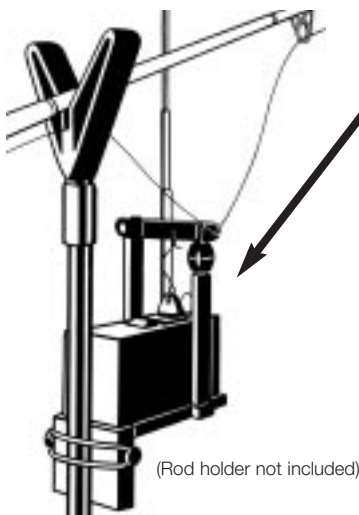

(Rod holder not included)

**OPTIONAL LINE MINDER
THE ULTIMATE STRIKE
SENSOR ACCESSORY FOR
BANK OR PIER FISHING!**

Secures transmitter to any rod holder and provides a built-in, adjustable tension trip arm.

- Strong ABS plastic
- Attaches quickly & easily to any rod holder or bank stick
- To set, simply run line through slot on trip arm
- Any tension on the line will lift the trip arm and activate the transmitter
- Tension on flip-up trip arm is completely adjustable

FULL 90 DAY WARRANTY

Any SensorTronics product which does not perform satisfactorily due to defects in workmanship or materials, which has not been misused, carelessly handled, or defaced by repairs made or attempted by others, will be replaced or repaired free of charge within 90 days of purchase date. **Do not return product to place of purchase.** Send the defective unit to:

**SensorTronics
120 W. Main, P.O. Box 509
Campbellsport, WI 53010**

If a defective product is returned to place of purchase, proof of purchase is required, and **all original equipment** packaged in the initial purchase must be returned with the product.

This warranty gives you specific legal rights. You may also have other rights, which vary from state to state. This warranty applies only to SensorTronics products sold within the United States and Canada.

FOR CUSTOMER SERVICE CALL 1-920-533-3624

STRIKE SENSOR AND ACCESSORIES

- Pager/Transmitter Pack \$55.00
- Extra Transmitters \$25.00
- Line Minder (shown above w/rod holder) \$9.00
- Transmitter Keys (3 pack) \$4.00
- Carrying Case (holds and protects up to 4 units) \$14.00

***Orders \$25 and over, include \$4.50 shipping & handling**

To purchase additional units for earlier versions, call Customer Service for prices and availability. 1-920-533-3624

For additional products and accessories, product information, battery specs and recommendations, visit our website at www.strikesensor.com

**TO ORDER CALL TOLL FREE
1-888-248-6992**

For fastest service, call toll free and order by credit card, or send check or money order to:

**SensorTronics
P.O. Box 509
Campbellsport, WI 53010**

Please include appropriate sales tax.

THANK YOU FOR YOUR ORDER